

Magnadrum clarifier Type FM1200

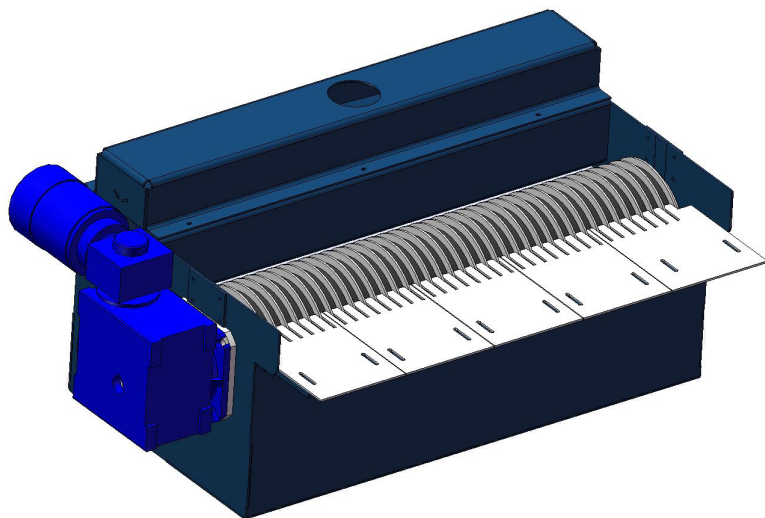

Design

The "Magnadrum" continuously removes magnetic particles from the flow of liquid and deposits them into a bin.

The system is ideal for production machine tools cutting and grinding ferrous materials and will cope with high rates of swarf production. The "Magnadrum" is suitable for use with water based coolants and most neat oils.

The equipment is often married to other clarifiers acting as a very efficient prefilter. The legs can be cut to suit installation and top or back entry can be chosen. Variants exist to allow tank top mounting or to contain the dirty coolant under pressure supply. Your special requirements can be discussed before ordering and we should welcome your inquiry.

- Automatic operation
- Powerful magnets filter down to 30 - 40 mikron
- Almost dry solid despatch

Function

Operation is simple and automatic. Powerful ceramic magnets fill the core of the drum, which is partly immersed in the liquid. The magnetic field is carried into the liquid flow by steel discs, so that all liquid passes through the high intensity field. Ferrous contaminant is attracted to the discs and drawn from the liquid as the drum revolves.

The drum is cleaned continuously as it turns against a profiled scraper. Particles arriving from the drum push along the scraper until they fall into the bin, compressing out excess liquid which drains to rejoin the flow leaving the solids almost dry.

Technical data Type FM1200

Model	Flow rate l/m	Inlet height mm	Outlet height mm	Length mm	Article no
1210	60	546	239	211	76233140
1220	110	576	269	343	76233340
1230	140	576	269	439	76233540
1260	250	609	305	782	76233640
1280	350	785	466	1000	76234540