

Extraction Arm NEX S



The NEX S arm fulfills all requirements for use in environments containing explosive dust and gas, and with extremely high hygienic demands. It has a double earthed system and antistatic earthed ventilation hose that prevents static electricity and sparks. Open support arm system and hood of acid proofed polished stainless steel requires little maintenance and makes it easy to clean.

NEX S is approved for explosive environments and marked as follows according to the ATEX-directive 94/9/EC: EX II 2 D/G II: Group II, for use above ground. (Not for mining) 2: Equipment category 2, working in zone 1/21 D: To be used in environments with explosive dust G: To be used in environments with explosive gas. The arm is double earthed, by the helix in the hose and through the arm system.



- The arm is flexible in all directions and simple to position
- Completely closed profiles, for maximum protection
- All parts can be cleaned with liquids up to 80° C and with detergents with PH value up to 12
- The hose is mounted parallel to the support arm by straps, which makes the hose very easy to remove for cleaning

Pressure drop

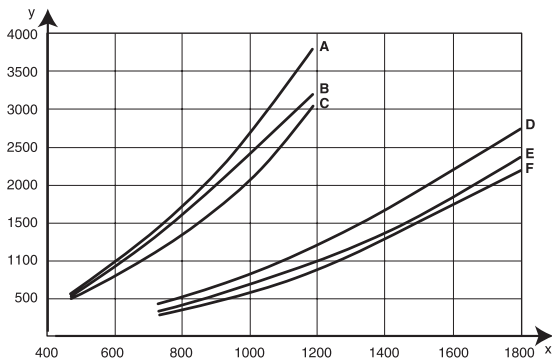

X: airflow m³/h Y: static pressure Pa A= 4 m Ø125 mm, B= 3 m Ø125 mm, C= 2 m Ø125 mm, D= 4 m Ø160 mm, E= 3 m Ø160 mm, F= 2 m Ø160 mm

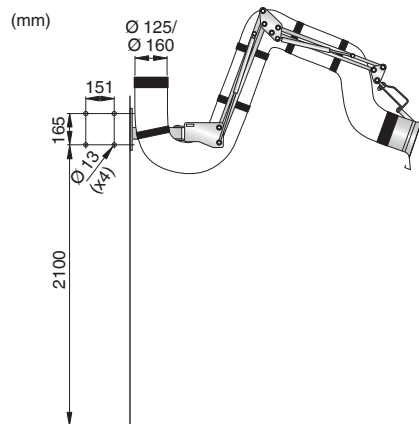

Description	Reach, m	Airflow, m ³ /h	Connection Ø, mm	Max. fume temperature, °C	Noise level at hood, dB(A)	Weight, kg	Part no.
NEX S 2m	2	550-1000	125	70	65	13	10520232
NEX S 3m	3	550-1000	125	70	65	14	10520332
NEX S 4m	4	550-1000	125	70	66	22	10520432
NEX S 2m	2	900-1700	160	70	71	20	10521232
NEX S 3m	3	900-1700	160	70	68	17	10521332
NEX S 4m	4	900-1700	160	70	70	24	10521432